



4PH-Fast CiTiceL[®]

Performance Characteristics

Nominal Range	0-5 ppm
Maximum Overload	20 ppm
Expected Operating Life	Two years in air
Output Signal	1.7±0.3 µA/ppm
Resolution	<0.05 ppm
Temperature Range	-20°C to +50°C
Pressure Range	Atmospheric ± 10%
Pressure Coefficient	No data
T₉₀ Response Time	<60 seconds
Relative Humidity Range	15 to 90% non-condensing
Typical Baseline Range (pure air)	-0.05 to +0.2 ppm equivalent
Maximum Zero Shift (+20°C to +40°C)	<0.07 ppm equivalent
Long Term Output Drift	<2% signal loss/month
Recommended Load Resistor	10 Ω
Bias Voltage	Not required
Repeatability	2% of signal
Output Linearity	Linear

N.B. All performance data is based on conditions at 20°C, 50%RH, and 1013 mBar

Physical Characteristics

Weight	5 g (approx.)
Position Sensitivity	None
Storage Life	Six months in CTL container
Recommended Storage Temperature	0-20°C
Warranty Period	12 months from date of despatch

Outline Dimensions

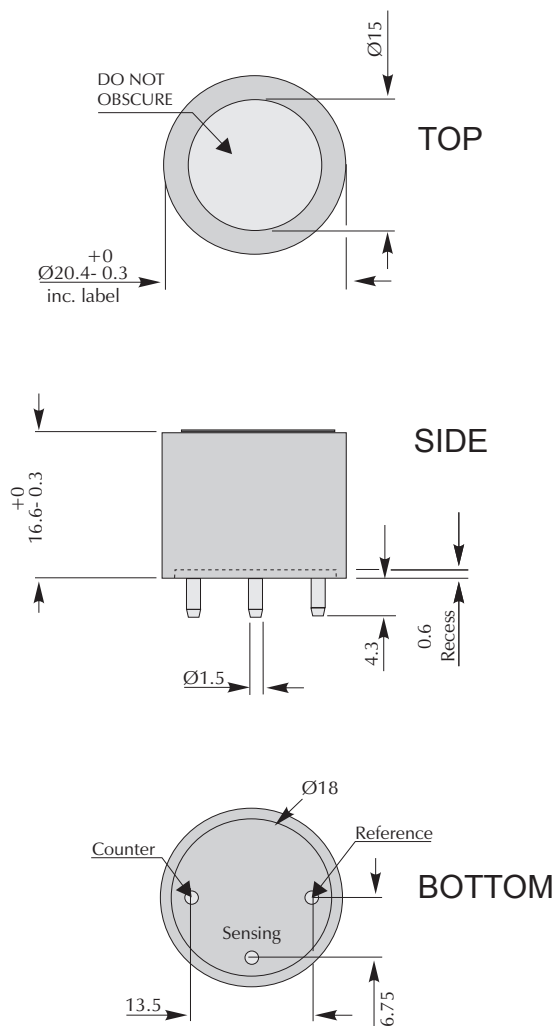

All dimensions in mm
All tolerances ±0.15 mm unless otherwise stated

IMPORTANT NOTE: Connection should be made via PCB sockets only. Soldering to the pins will seriously damage your sensor.



Cross-sensitivity Data

CiTiceLs may exhibit a response to certain gases in a sample other than the target gas. 4PH CiTiceLs have been tested with a number of commonly cross-interfering gases and the results are given below. The table shows the typical response to be expected from a sensor when exposed to a given test gas concentration (relevant to safety, e.g. TLV levels).

Gas	Conc.	4PH	Gas	Conc.	4PH
Arsine:	150ppb	100ppb	Sulphur dioxide:	5ppm	1ppm
Silane:	1000ppb	900ppb	Hydrogen:	1000ppm	1ppm
Diborane:	300ppb	105ppb	Ethylene:	100ppm	1ppm
Germane:	600ppb	550ppb	Carbon monoxide:	1000ppm	5ppm

For details of other possible cross-interfering gases contact City Technology.

SAFETY NOTE

This sensor is designed to be used in safety critical applications. To ensure that the sensor and/or instrument in which it is used, are operating properly, it is a requirement that the function of the device is confirmed by exposure to target gas (bump check) before each use of the sensor and/or instrument. Failure to carry out such tests may jeopardize the safety of people and property.

Every effort has been made to ensure the accuracy of this document at the time of printing. In accordance with the company's policy of continued product improvement City Technology Limited reserves the right to make product changes without notice. No liability is accepted for any consequential losses, injury or damage resulting from the use of this document or from any omissions or errors herein. The data is given for guidance only. It does not constitute a specification or an offer for sale. The products are always subject to a programme of improvement and testing which may result in some changes in the characteristics quoted. As the products may be used by the client in circumstances beyond the knowledge and control of City Technology Limited, we cannot give any warranty as to the relevance of these particulars to an application. It is the clients' responsibility to carry out the necessary tests to determine the usefulness of the products and to ensure their safety of operation in a particular application.

Performance characteristics on this data sheet outline the performance of newly supplied sensors. Output signal can drift below the lower limit over time.